

A Review on Solar Power Management System

Subham Mukherjee¹

M-Tech Scholar
BIT, Durg, Chhattisgarh, India

Mr. Mousam Sharma²

Assistant Professor
BIT, Durg, Chhattisgarh, India

Mr. Brahma Nand Thakur³

Assistant Professor
BIT, Durg, Chhattisgarh, India

Abstract: Solar power is the major renewable energy source opted by developing countries as stand-alone / Grid enabled system. Industries and educational institutions are opting for solar energy to combat power crisis. This paper proposes knowledge based, self-configurable, smart controller to efficiently use solar energy according to load, under frequent grid failure environment. It is enabled with fault identification and isolation. Extension to higher power capacity is easily achieved with plug and play mechanism. It can be used with low power as well as high power photo-voltaic system. The efficiency of the proposed construction is reflected in the photo-voltaic system installed in the educational institution.

Keywords: Solar, photovoltaic, system, management, review

I. INTRODUCTION:

Recent applications of high-power PV (Photo-Voltaic) system utilize advanced techniques such as Distributed Maximum Power Point Tracking (MPPT), converter per panel and multi-level converters¹. Distributed MPPT exhibits more losses due to mismatch in different PV modules. Module Integrated Converters (MIC)² are developed to reduce these losses. They are used to integrate PV system with Grid, future energy delivery, dc link etc³⁻⁶ Multi-level converters/inverters are preferred for improved power quality⁷ with lower harmonic distortion⁸⁻⁹. Design of multi-level system controller is complex and high-end hardware is required to generate multiple switching pulses¹⁰⁻¹¹. Necessary high frequency switching signals of these systems are generated by CMOS implementation of controller¹²⁻¹³. Very Large Scale Integrated (VLSI) circuit technology provides optimum solution to the design issues of modular integrated / multi-level converters. Efficient energy management is another prime requirement of photo-voltaic system. Adika and Lingfeng proposed load scheduling algorithm for efficient energy consumption. Simulation results of this algorithm shows savings in energy cost of 9.43% and pricing of 10.92%. Installations of solar photovoltaic (PV) and wind are steadily increasing due to exhaustion of fossil fuels, its price variation, instability in trading of coal/crude oil, and issues of greenhouse gases¹. Utilizing more renewable energy sources (RES) minimizes the dependency on imported fossil fuels and creates sustainable energy production. However, RES is highly intermittent and fluctuating in nature. Particularly, the PV system is highly reliant on climatic or geometrical conditions and output power severely oscillates during bad climatic situations. The higher fluctuations in the injected power will seriously affect the power system stability. Hence, the energy storage system (ESS) is an essential element to mitigate these variations and improves the system power quality²⁻³. Generally, the ESSs are a battery, super-capacitor (SC), flywheel, and superconducting magnetic energy storage (SMES), etc. The battery is a continuous power application device and usage is popularly increasing worldwide. The need for high power and energy demand can be achieved by combining battery and SC devices called as HESS and it is interfaced with a DC link employing bidirectional converters, which allows power into and from the ESS devices⁴⁻⁵. The importance of these ESSs can perform a significant role in the context of microgrid (μ G) system.

Generally, the group of sources associated together to form a μ G such as distributed energy sources, storage systems, and loads. μ Gs are categorized as DC, AC, and hybrid μ Gs. The hybrid μ G is the combination of AC and DC μ G. The DC μ G is more preferred over the AC μ G. It has various benefits such as better efficacy, less control complexity, and low power loss due to fewer conversion stages⁶. The benefit of a DC power system is the lack of reactive power over an AC

power system. Reactive power leads to a loss of power in the lines, over-size of the inverters and the DC bus capacitors, and decrease in the line power transmissions' ability that affects AC power systems' efficiency and their reliability. Nevertheless, only active power in the lines is transmitted in DC μ Gs that reduce the sizing of wire and DC bus capacitors. The DC μ Gs are thus more efficient and reliable than AC μ Gs. In the meantime, it will reduce costs further by eliminating the power conversion stages for complete converter sources and variable-speed drives. Harmonic nonlinear load currents increase energy loss in lines, transformers, and converters, thus reducing transformers and converters efficiency in AC μ Gs. In addition, nonlinear loads affect the control system and, in some cases, also cause instability. Due to the high permeability of nonlinear loads in power distribution systems, DC μ Gs are again preferred to AC μ G from the point of view of performance, reliability, and stability. The regulation of DC μ Gs is very simple compared to AC μ Gs as the power is regulated by the DC bus voltage and the angular and frequency stability control complexity does not show up in DC μ Gs. Thus, DC μ G appears to be efficient, reliable, and economical⁷. The μ Gs are performed in two modes such as grid-connected and stand-alone mode. In stand-alone mode, the power balance is achieved by the ESS. During grid-connected operation, the grid can provide the balance power as the number of sources is correlated to sufficient demand of the load⁸. A typical DC μ G is shown in Figure 1. In this, the RESs and ESSs are linked to the DC bus through interfacing converters. The ESSs in this system can be used to limit the PV power variations as well as maintain power stability. These converters work in parallel and there is a necessity to sustain the power balance at the DC link⁹. The instantaneous power balance is obtained from the following equation.

$$P_{in}(t) = p_{dc}(t) + p_{out}(t) \dots\dots\dots(1)$$

where, $p_{in}(t) = p_{res}(t) + p_{ess}(t)$ and $p_{out}(t) = p_{dcl}(t)$, $p_{res}(t)$ is the power from RES, $p_{dcl}(t)$ power absorbed by the DC link capacitor, and $p_{ess}(t)$ is the power from ESS.

II. REVIEW:

EMS has an important task in EV due to increasing the number of subsystems, components and energy storage devices. AC is the main concern of EV to consume energy. The most common energy storage device in EV is the battery. Due to more weight and long charging time, battery has some drawback. To overcome the limitation of battery high power ultra-capacitors and fuel cell are used. ESS can be designed by installing the battery with high capacitance and this is called as hybrid Energy Storage System (ESS) [1]. Author briefed about three parts, ESS, load control application and asynchronous controller. ESS is the main part of the EV. To designing the ESS controller Null Conventional Logic (NCL) is used. NCL provides low energy consumption with efficient time .

Electric Drive Vehicle (EDV) has many advantages than the gasoline vehicle. Battery charging and discharging can be controlled by EMS in EV. EMS is very efficient to managing the energy in EV. In EDV, battery storage is one of the most components. Battery in EDV can be charged from the power grid. The charging station consists of AC/DC convertor for grid interface and multiple DC/DC convertors for battery management [2]. The author has explained variable charging and discharging conditions of battery with physical constraints of power convertors

Solar/Electric/Fuel Powered Hybrid Vehicle (SEFPHV) system which solves the major problem of fuel and pollution. Hybrid Powered Vehicle is the combination of multiple sources. The vehicles will run with the help of solar power, electric power and less amount of fuel [3]. Rechargeable batteries are used to drive the BLDC (Brushless DC) motor in vehicle. The hybrid vehicles are run on solar power as well as on the engine. SEFPHV system uses the three sources are solar power, plug in electric power supply and IC engine. The advantage of the hybrid vehicle is to reduce the pollution, greenhouse effect and CO₂ emission. In this method very, less amount of fuel is used. They discussed that there are three modes of operation in hybrid vehicle. In mode 1, two solar panels are used. Each solar panel having the solar energy is 230watt. In mode 2, two stroke IC engine. In mode 3, plug in energy source (with step down transformer and diode rectifier). The main two systems used are BLDC motors, PMDC (Permanent Magnet DC) generators. With this method many problems related to the environment are solved by hybrid powered vehicle technology .

The increasing demand of vehicles forced to convert technique solution with hybrid EV. In this hybrid vehicle IR speed sensor and PWM methods can be used for controlling the speed of the vehicle. This method may be efficient to improve the performance of EV [4]. A solar powered Air conditioning system (SAV) is presented to replace the conventional system. Using photovoltaic technique and intelligent power control, SAV switches on board AC to solar power when

petrol engine shuts off. This system continues to keep the AC system on during the sunny days even when the vehicle engine is switched off. They claimed that adapting this system can help to save driver petrol and fuel cost of 100 liter for one year [5] .

A solar powered Air conditioning system (SAV) is presented to replace the conventional system. Using photovoltaic technique and intelligent power control, SAV switches on board AC to solar power when petrol engine shuts off. This system continues to keep the AC system on during the sunny days even when the vehicle engine is switched off. They claimed that adapting this system can help to save driver petrol and fuel cost of 100 liter for one year [5] .

III. Smart photovoltaic system:

Proposed controller uses single processor to generate control signals required for PV module and energy management. It uses minimum number of switching devices for various applications of PV system like battery charging, supply peak load / AC grid. Full bridge inverter topology is chosen for the architecture. Schematic of proposed switching module for single stage. Fast switching relays like Phoenix contact DPDT MR 12VDC/21-21, could be used for switches SW1-SW5. Seamless operation is achieved using soft start routine and initializing the relay before its switching delay of 7ms. Power MOSFET device (Metal Oxide Semiconductor Field Effect Transistor) IRFP150PN is used for transistors Q1-Q4

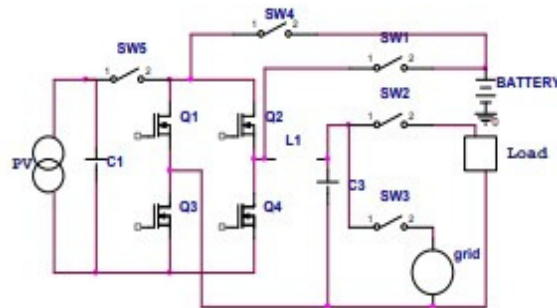

Figure 1: Proposed Single Stage Switching Module

Table 1. Operating modes of proposed system

Source	Operation	Control signals
Solar Power	Battery charging	SW1, SW5, PWM for Q2
Solar Power	Supply AC load	SW2, SW5, Sine PWM for Q1-Q4
Solar Power	Supply AC grid	SW3, SW5, Grid synchronized Sine PWM for Q1-Q4
Battery power	Supply AC load	SW2, SW4, Sine PWM for Q1-Q4

Solar power is utilized to supply load as shown in figure 2. Photo-voltaic cell is connected to load through full bridge inverter and filter. Transistors Q1-Q4 are applied with sine PWM control signals generated by the controller.

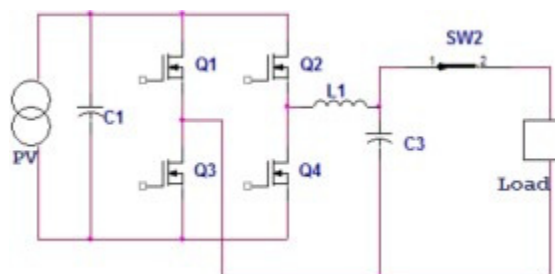

Figure 2. Solar power supplying load

In addition to the charging and battery mode, the solar power is connected to the grid as shown in Figure 3. Synchronized sine PWM signals produced on transistors Q1-Q4. With solar power availability and load condition absent, the battery charging is available as shown in Figure 4. PWM-based battery charging is used to perform control.

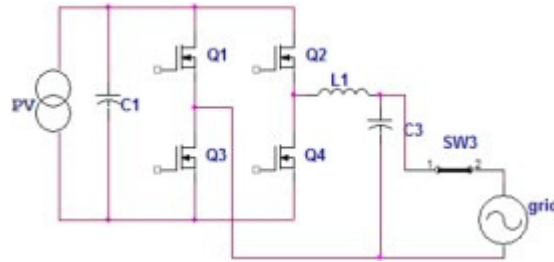

Figure 3: Solar power interfaced with grid signals,

which activate switch sw1 and transistor Q2.

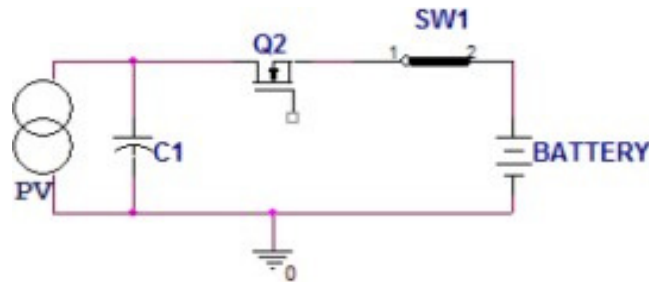

Figure 4: Battery Charging mode

To meet load requirements during evening hours, battery is used to supply load as shown in figure 5.

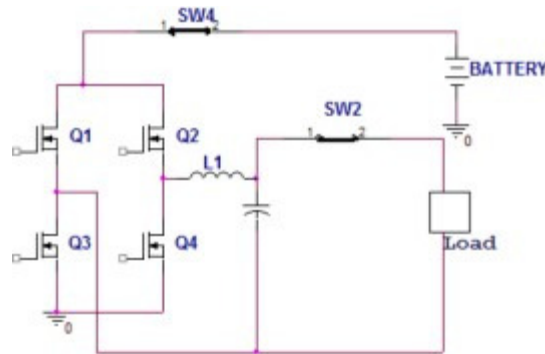

Figure 5: Battery supplies load in the absence of solar power

The display indicators for the proposed control of a single photovoltaic system are shown in Figure 7. Solar panel power, current power, battery power and current load are the input features of the controller action. Analog to digital converter ADC0808 converts these analog signals into an 8-bit digital signal. Eight ADC input channels can be used with two PV phases. The control signals required for ADC (ALE, SOC, EOC, OE), switch (SW1-SW5), and transistors (Q1-Q4) are produced by the controller. The status of each PV module is also displayed by the output signal. Grid sync input is common in all PV modules. Input 'mode' determines the operating system of the controller. Two photovoltaic modules require 35 control / output control pins.

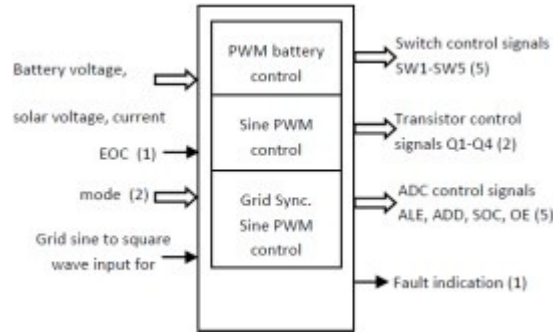

Figure 6: Interface signals of smart controller for single stage PV system

The main functional modules of the controller are the battery charging controller, the PWM controller and the PWM Grid synchronized controller. Depending on the operating mode, one of the controllers is active. The state flow model of the controller is shown in Figure 7. The independent operating mode of each module enables the configuration of various types of power supply for multiple levels. Under incorrect conditions, all control signals are disabled and switches are turned off. The control modes are modeled on the Xilinx ISE 12.2 simulation platform.

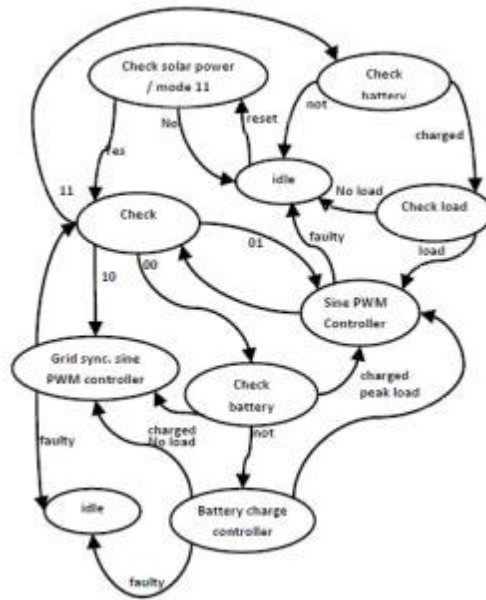

Figure 7: State Flow Model of proposed controller

IV. Battery Charge Controller:

It is activated in 00 mode and detects battery power, to get charging status. When not charged, a battery charging algorithm is generated to produce a PWM signal for transistor Q2, as well as SW5 and SW1 control signals. Once the battery is fully charged, the PWM controller with the PWM / grid synchronized is activated according to the loading requirement. The input and output signals of this controller are shown in Figure 8. The simulation results for this controller are shown in Figure 9 and the PWM signal of a 50% activity cycle. The PWM signal function cycle varies by selecting the appropriate calculation value. An error is displayed, if the battery power remains constant for a long time, while charging.

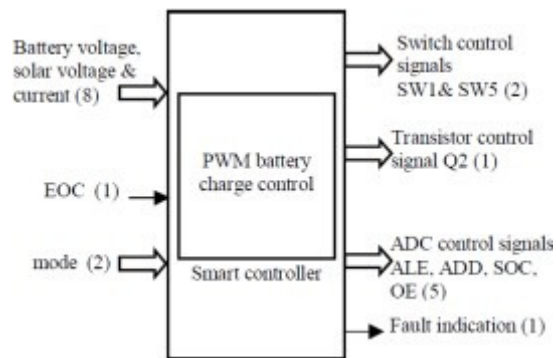

Figure 8: Battery charge controller interface

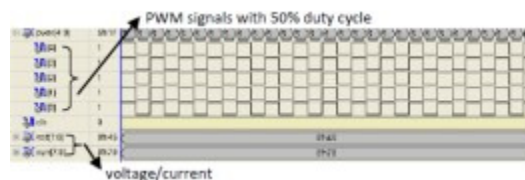

Figure 9 PWM signal output for five stages

Sine PWM signal is generated using sine look up table with triangular wave carrier signal. Frequency of sine PWM is varied by changing count used for signal generation. It is activated in mode 01 and mode 11.

V. Conclusion and future work

An effective power management system for a modular multi-level photo-voltaic system is developed using FPGA. A major contribution of this work is the development of control signals for multiple PV modules taking into account the effective power management system. Many of the proposed PV controller includes the performance of a power management system. The performance of this proposed technology using a micro-processor / controller or digital signal processor is limited to a few inputs / outputs. FPGA supports multiple input / output signals compatible with all modules. The power of the PV System can be easily expanded without affecting the existing functional modules. The performance of a smart controller is indicated by a photo-voltaic system suitable for an educational institution with different load conditions. Input / output requirements and control signals for various operating modes are discussed. Simple algorithms such as a PWM-based charger and a sine PWM generator are selected for the controller. Changing the module for this research work uses fewer numbers of transistors. Industries are developing high-tech solutions in the field of solar energy, by supporting this type of research in academics. The efficiency of the system is the same as that of the contract.

References:

- [1] Maryam Saedifard, Peter, Mantovanelli Barbosa, and Peter K. Steimer, "Operation and Control of a Hybrid Seven-Level converter," *IEEE Trans. Power Electron.*, vol. 27, No. 2, pp. 652-660, February 2012.
- [2] Carlos Olalla, Daniel Clement, Miguel Rodriguez, and Dragan Maksimovic, "Architectures and Control of Sub module Integrated DC-DC Converters for Photovoltaic Applications," *IEEE Trans. Power Electron.*, vol. 28, No. 6, pp. 2080-2997 June 2013.
- [3] Zhigang Liang, Rong Guo, Jun Li, and Alex Q. Huang, "A High-Efficiency PV Module-Integrated DC/DC Converter for PV Energy Harvest in FREEDM Systems", *IEEE Transactions on Power Electronics*, Vol. 26, No. 3, pp. 897-908, March 2011.

- [4] Q. Li and P. Wolfs, "A review of the single phase photovoltaic module integrated converter topologies with three different DC link configurations," *IEEE Trans. Power Electron.*, vol. 23, no. 3, pp. 1320–1333, May 2008.
- [5] Giovanni Petrone, Giovanni Spagnuolo, Massimo Vitelli, "Distributed maximum power point tracking: challenges and commercial solutions," *Automatica* 53(2), 128–141, Apr 2012.
- [6] S. Jiang, D. Cao, Y. Li, and F. Z. Peng, "Gridconnected boost-half-bridge photovoltaic microinverter system using repetitive current control and maximum power point tracking", *IEEE Trans. Power Electronics.*, vol. 27, no. 11, pp. 4711–4722, Nov. 2012.
- [7] Keith A. Corzine Mike W. Wielebski, Fang Z. Peng, and Jin Wang, "Control of Cascaded Multilevel Inverters," *IEEE Trans. Power Electronics.*, vol. 19, No. 3, 281-289, May 2004.
- [8] G.Preethi, J. Gayathri Monika, v.Jamuna, "Digital Simulation of Multicarrier PWM Strategy for MultiLevel Inverter," presented at the International Conference on Computing, Electronics and Electrical Technologies [ICCEET], 2012.
- [9] Hyuntae Choi, Wei Zhao, Mihai Ciobotaru, Vassilios G. Agelidis, " Large-Scale PV System based on the Multiphase Isolated DC/DC converter", presented in 3rd IEEE International Symposium on Power Electronics for Distributed Generation Systems (PEDG) , pp. 801-807, 2012.
- [10] Ay,se Kocalmis, Sedat Sünter, "Application of a Neural Network Based Space Vector PWM Algorithm To Multi-Level Inverters," Published in International Aegean Conference on Electrical Machines and Power Electronics, pp. 181-185, Sep10-12, 2007.
- [11] R. Rabinovici D. Baimel J. Tomasik A. Zuckerberger, "Series space vector modulation for multi-level cascaded H-bridge inverters" *IET Power Electronics*, Vol. 3, Iss. 6, pp. 843–857, 2010.
- [12] Reinhard Enne, Miodrag Nikolic, and Horst Zimmermann, "Dynamic Integrated MPP Tracker in 0.35 μm CMOS," *IEEE Trans. Power Electron.*, vol. 28, No. 6, pp. 2886-2894, June 2013.